

MOUNTING INSTRUCTIONS

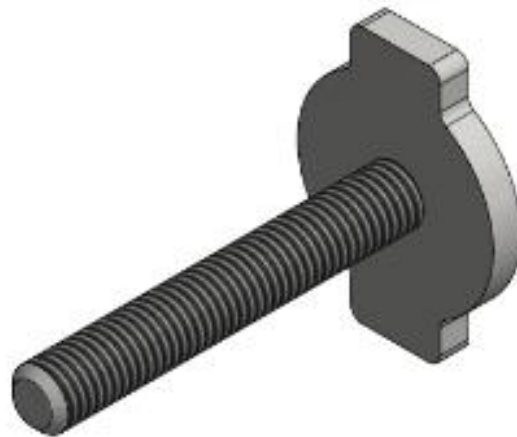

3D - LIFTING SYSTEMS | IPD FIXING PLATE WITH THREADED ROD



ATTACHMENT OF THE SLOT - ANCHORS IN CONCRETE

There must be a cavity in the concrete in order to link the TH2 lifting clutch to the T-slot anchor. This cavity is spherical in shape and can be either a half ball or a small ball slot. Various support kits are available for making this recess. For a half ball cavity, the TH2 lifting clutch can be attached in any direction and can ultimately turn in the cavity during lifting until the lifting hook has reached its proper position. The RB recess former is the most practical.

RECESS FORMERS

The anchors are fitted in the mould with a recess former. The cavity former, enables the lifting clutch to fit over the anchor. Because of the special design, there are no sharp edges on the precast element. The recess formers are of course available in the same range as the lifting clutches and the anchors. This is indicated by a load group, marked on the top.

The formers are mounted on the mould with fixing plates. After demoulding the element, the recess formers can be removed easily. Another option is represented by the magnetic and steel recess formers.

The standard recess formers are made of rubber shore 65° - 70°. The rubber used has a good resistance to demould oil. The formers will keep their original shape, even when they are heated up to 120°C. They can be used many times. The steel magnetic recess formers are manufactured without rubber.

IPD – FIXING PLATE WITH THREADED ROD / IPDV – FIXING PLATE WITH THREADED ROD AND WING NUT

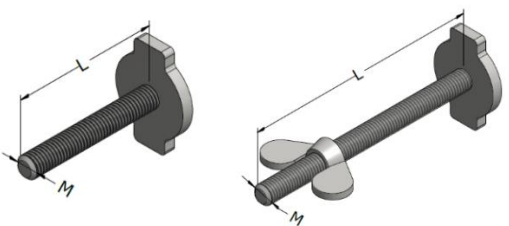
| Fixing plate with threaded rod IPD | | Fixing plate with threaded rod and wing nut IPDV | | Load group | Thread | L | IPD | IPDV |
|------------------------------------|-------------|--|-------------|------------|--------|-----|---|------|
| Description | Product no. | Description | Product no. | | | | | |
| IPD-013 | 44051 | IPDV-013 | 43081 | 13 | M 8 | 100 |  | |
| IPD-025 | 44052 | IPDV-025 | 43082 | 25 | M 10 | 100 | | |
| IPD-050 | 44053 | IPDV-050 | 43083 | 50 | M 10 | 100 | | |
| IPD-075/100 | 44054 | IPDV-075/100 | 43084 | 75/100 | M 12 | 100 | | |
| IPD-150/200 | 44055 | IPDV-150/200 | 43085 | 150/200 | M 12 | 100 | | |
| IPD-320 | 44056 | IPDV-320 | 43086 | 320 | M 16 | 100 | | |

GENERAL INSTRUCTIONS FOR INSTALLATION AND USE

RUBBER RECESS FORMERS

- If the formwork can only be removed sideways, the fixing plate with a threaded rod IPD or IPDV should be used.

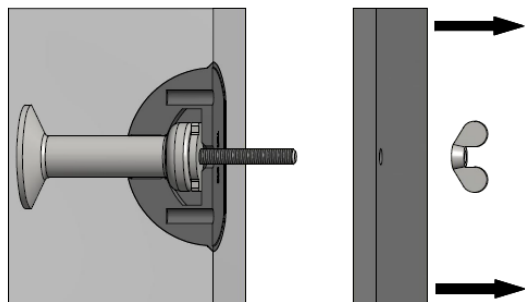

- If the formwork can only be removed vertically, the fixing plate IP in combination with the threaded screw TDV should be used.

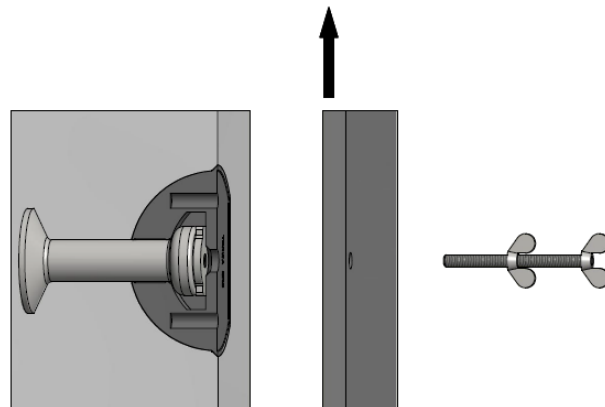

- The fixing plate with a threaded rod IPD or IPDV and the anchor are fitted in the opened recess former. The recess former is mounted to the formwork with the wing nut. The nut is then tightened securing the recess former and the anchor firmly in position.

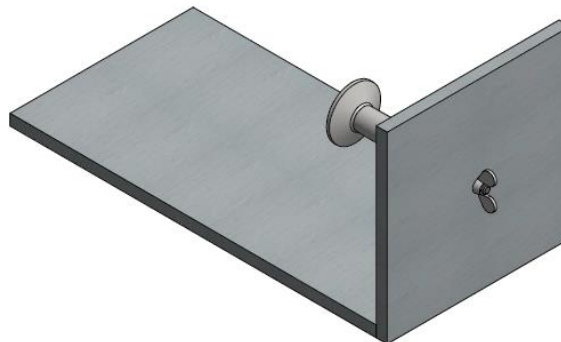
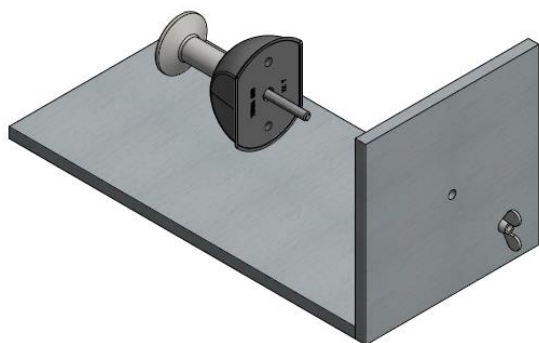

- For wooden formwork, the recess former can be mounted with the OPR mounting plate. The pins on the OPR ensure that the recess former remains closed when pouring concrete. The OPR is mounted on the formwork with nails.

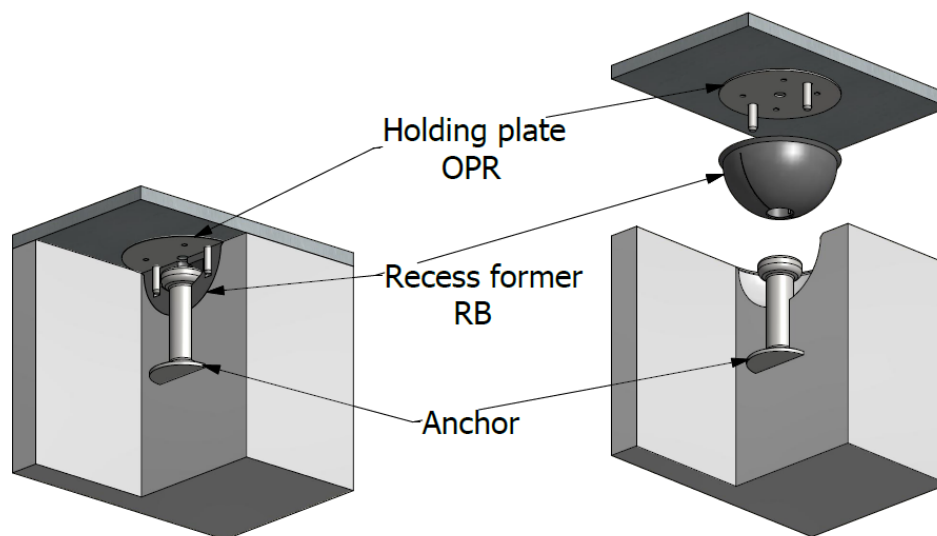

ANCHOR - INSTALLATION

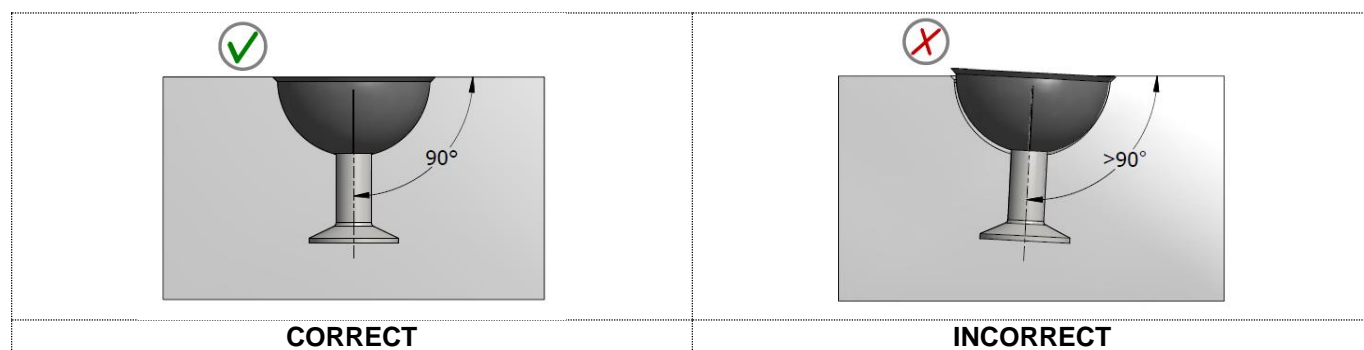

REMOVAL OF THE RUBBER RECESS FORMER

Two pieces of rebar steel can be inserted in the recess former holes. Using these rods, the former bends open and can be removed from the anchor. Excessive concrete should be removed beforehand. Do not use a hammer or any other tools, as these can damage the recess former.

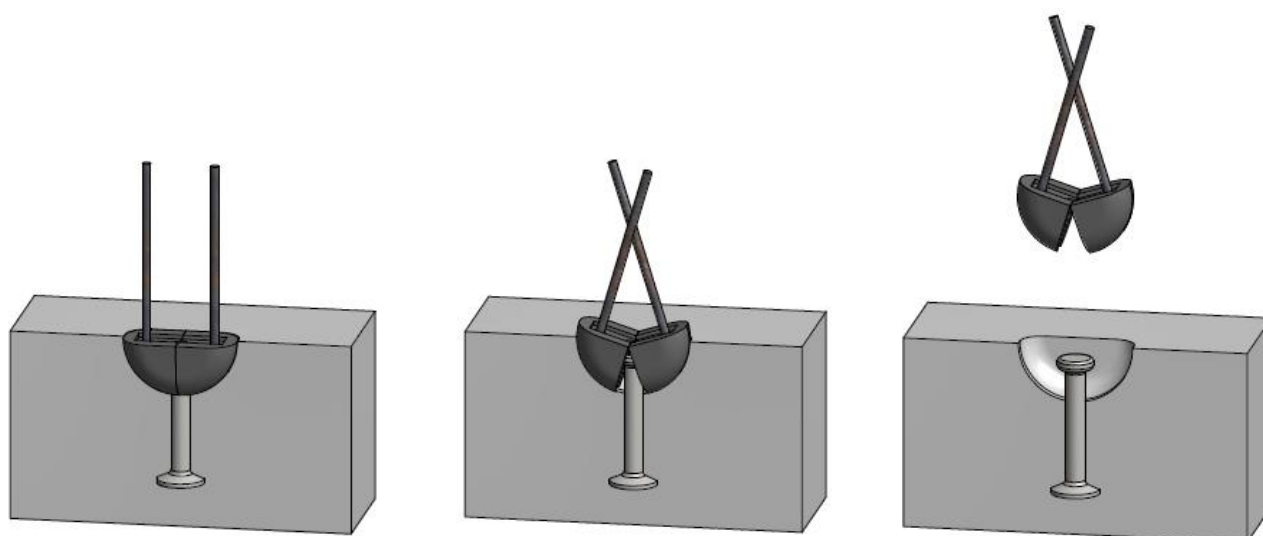

STEEL RECESS FORMER

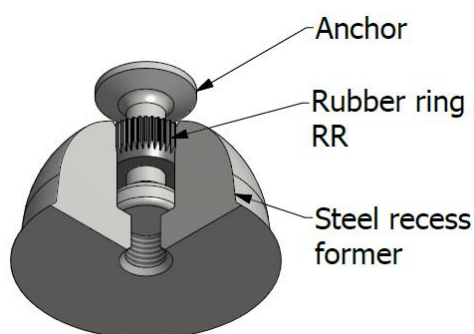

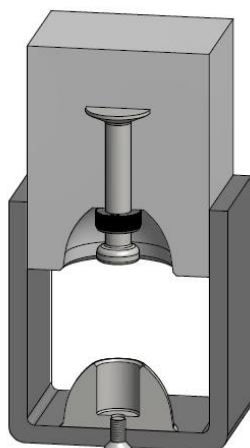
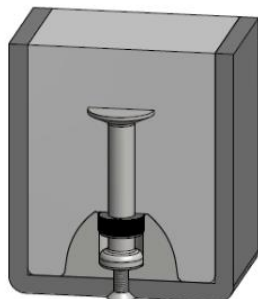
Steel recess former - SBK

The steel recess formers SBK and SBKM are always used in combination with a rubber ring. The rubber ring ensures that the anchor fits snugly in the former. Moreover, the rubber ring prevents concrete pouring into the recess former. We recommend lubricating both the anchor head and rubber ring with formwork oil before installation. When the precast element is lifted out of the mould, the anchor and rubber ring detach themselves easily from the recess former.

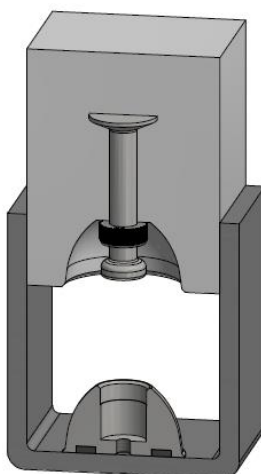
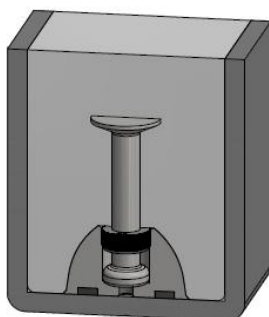
Steel recess former with magnets - SBKM

When using this magnetic recess former, it is very important that the surface of the formwork is clean. After demoulding, the magnetic former can be removed from the formwork with a screw.

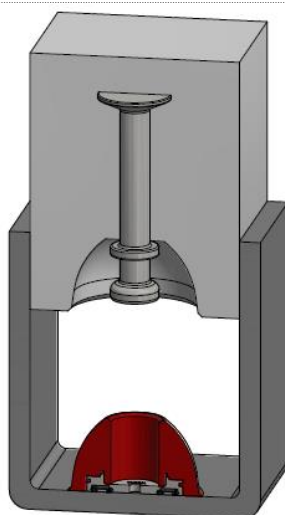
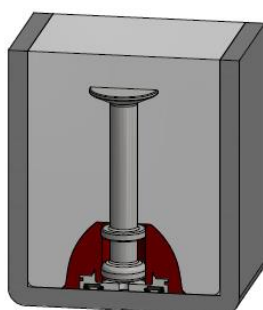
Magnetic recess former for P-anchor - MPB

The MPB recess former with magnets is made of polyurethane resin and is used in combination with P anchor. These recess formers are mostly applied in an upside down position.

CONTACT



TERWA is the global supplier for precast and construction solutions with multiple offices around the world. With all our staff, partners and agents, we are happy to provide all construction and precast companies who work in the building industry with full service and 100% support.

TERWA CONSTRUCTION GROUP

Terwa Construction Netherlands (HQ)

Global Sales & Distribution
 Kamerlingh Onneslaan 1-3
 3401 MZ IJsselstein
 The Netherlands
T +31-(0)30 699 13 29
F +31-(0)30 220 10 77
E info@terwa.com

Terwa Construction Central East Europe

Sales & Distribution
 Strada Sânzieni
 507075 Ghimbav
 Romania
T +40 372 611 576
E info@terwa.com

Terwa Construction Poland

Sales & Distribution
 Ul. Cicha 5 lok. 4
 00-353 Warszawa
 Poland
E info@terwa.com

Terwa Construction India & Middle East

Sales & Distribution
 India
T +91 89 687 000 41
E info@terwa.com

Terwa Construction China

Sales & distribution
 5F 504, No. 101 Chuanchang road
 PRC, 200032, Shanghai
 China
E info@terwa.com

ALL SPECIFICATIONS CAN BE CHANGED WITHOUT PREVIOUS NOTICE.

DISCLAIMER

Terwa B.V. is not liable for deviations due to wear of the products it has delivered. Neither is Terwa B.V. liable for damage due to inaccurate and/or improper handling and use of the products it has delivered and/or use of same for purposes other than those intended.

Terwa B.V.'s responsibility is furthermore limited in accordance with article 13 of the "Metaalunie" conditions, which are applicable for all Terwa B.V. deliveries. The user is responsible for ensuring compliance with all applicable copyright laws. Without limiting the rights under copyright, no part of this documentation may be reproduced, stored in or introduced into a retrieval system, or transmitted in any form or by any means (electronic, mechanical, photocopying, recording, or otherwise), or for any purpose, without the express written permission of Terwa B.V.